

## ISOPur HR Agglomerator™ with BCA Technology

### Treatable Fluids

- Lubricating oil
- Hydraulic oil
- Phosphate ester
- Machining oil
- Diesel fuel
- Vegetable oil
- EDM fluid
- Dielectric fluids
- Turbine oil
- Many other non-conducting fluids



Are you concerned with the performance of your oil/fluid filtration system? Do you have continued problems with varnish and sludge formation on critical machinery internals? The HR Agglomerator™ can help. ISOPur's patented Balanced Charge Agglomeration (BCA) technology, grows sub-micron particles into larger particles which improves existing filter performance. The HR Agglomerator™ also removes and prevents sludge and varnish buildup, providing a complete fluid purification solution.

---

**ISOPur makes filters work better by making particles larger.**

---

### What is BCA?

Balanced Charge Agglomeration works by pumping non-conducting fluids past electrodes that ionize contamination particles equally positive (+) and negative (-). The oppositely charged particles are mixed, attract to each other, and grow in size. These agglomerated particles are then easily removed by traditional filtration methods.

### HR Agglomerator™ Features

- Agglomerates smaller particles into larger, filterable particles
- Effective on particles down to 0.1 microns in size
- Substantially improves existing filtration performance
- Stops and removes existing sludge & varnish from machinery
- Agglomerates oxide insolubles and biological contamination
- Flow rates to 20+ gpm
- Improves water and air separability characteristics
- Optional pump and motor assembly

---

**ISOPur's patented BCA technology stops & removes varnish.**

---

## HR Agglomerator™ Specifications

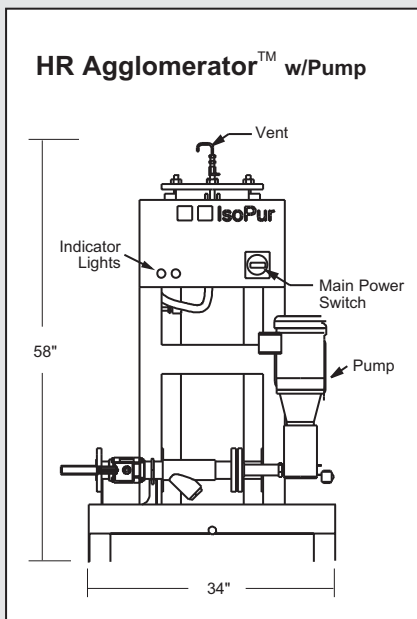
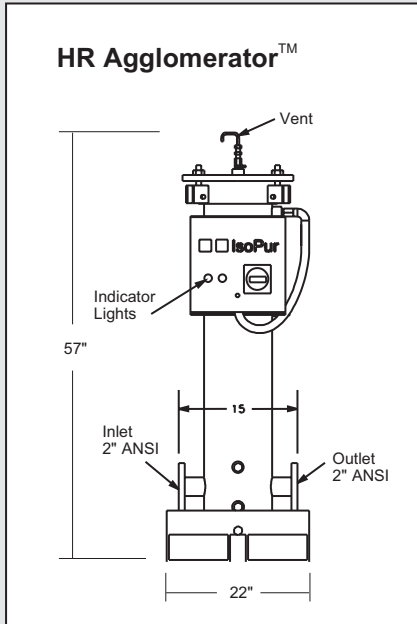

	USA	International
Flow rate	600 to 1200 GPH	2300 to 4500 LPH
Dimensions		
without pump/motor	57in x 22in x 18in	145cm x 56cm x 46cm
with pump/motor	58in x 34in x 26in	173cm x 86cm x 66cm
Weight dry		
without pump/motor	320 lbs	145 kg
with pump/motor	570 lbs	259 kg
Weight wet		
without pump/motor	425 lbs	193 kg
with pump/motor	680 lbs	308 kg
Pump discharge pressure	12 to 80 PSIG	0.7 to 5.5 Bars
Fluid temperature range*	65 to 200 F	18 to 93 C
Minimum fluid flash point	140 F	60 C
Pump/motor type	Variable Speed	
RPM	900 to 1800	
Power	1.5 hp	1.12 Kw
Mains supply (Volts/Hz)	220-480/60	230-400/50
Amps	Dedicated 15 amp branch service	
Fluid viscosity*	2 to 220cSt at 40 C	
Ambient humidity range	Up to 95% non-condensing	
Transportation & storage	0 to 132 F	-18 to 55 C
Suction connection	2" ANSI raised flange	5.1 cm
Discharge connection	2" ANSI raised flange	5.1 cm

### 3 Micron Filter Performance Comparison With vs. Without Agglomerator Technology

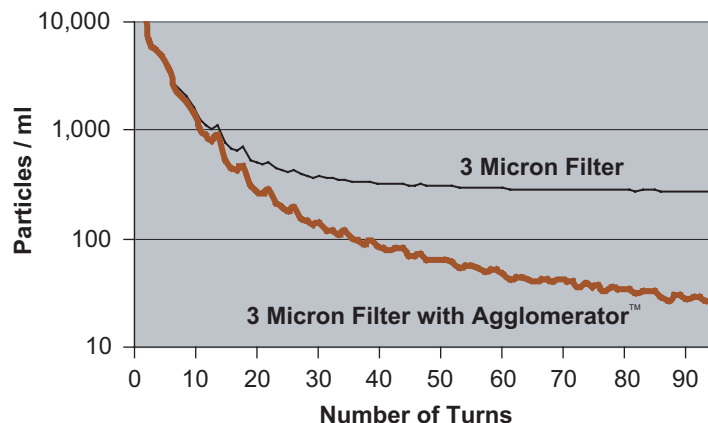

- New Mobile DTE-797 oil purifying at 50 gal/hr
- 3 micron filter, beta 75
- Contaminant type: Arizona fine test dust, analysis 4604AA (0-3 micron)