



ECO 24P

Program controller

- 4 programs with 16 segments each
- Delayed program start (timer)
- Bandwidth monitoring in the 'hold' segment
- Program continuation after mains failure
- Cyclical program repeat
- PID controller with fuzzy support
- Up to three plug-in output modules for: mA, V, relay, SSR driver or triac
- External contact for program start / stop
- RS 485 with Modbus RTU protocol
- Front panel protection mode IP 66

economy line

GENERAL

Due to its extremely compact dimensions, the ECO 24P can be installed even in the smallest machines. Its universal input and the flexible modular concept for a wide range of output types enable the controller to be adapted perfectly to the most varied automation tasks.

Similarly, the unit is configurable as signaller, continuous, 2-point or 3-point controller for heating or cooling, as well as heating/cooling tasks, i.e. for universal applications. Moreover, 'split-range' operation is possible in all combinations (e.g. continuous/switching), and various alarm functions put a finishing touch to the comprehensive package.

PROGRAMMER

Up to 4 programs with 16 segments each of the types *Ramp*, *Hold*, or *End* are configurable.

Ramps are entered as *Gradient / Target value* or as *Time / Target value* (configurable).

At the end of a Hold segment, the program can either be continued automatically, or it waits for a start signal from the 'Run' key.

A control output (relay or logic) is assigned to each program.

An active program can be repeated cyclically as often as required (adjustable no. of repeats).

The programmer is started/stopped either from the front panel or via a

control input. A built-in timer permits a delayed program start.

A bandwidth monitor in each Hold segment stops the program automatically, if the process value exceeds the defined bandwidth.

Following a mains failure, the program can either be aborted (cold start; control with internal setpoint) or it can be continued from the actual process value (warm start).

The process value or the program setpoint is available as an analog signal at Output 3.

An active program can be interrupted via the front panel keys, whereby control continues with the internal setpoint (if this option is enabled), or the output can be controlled manually.

Setpoint, auto/manual mode, and the manually controlled output value are adjustable in the Operating Level.

SAFE OPERATION

The unit is operated by means of just 4 front-panel keys. Menu guidance simplifies navigation through the following levels:

- Operation
- Parameter adjustment
- Program definition
- Configuration
- Product information
- Self-tuning

Access codes prevent unauthorized adjustments. The extended Operating Level enables both setpoints to be adjusted, as well as the output value for manual operation.

Short texts for all adjustment parameters simplify the unit's configuration via the front panel. Alternatively, every unit comes with an interface for remote configuration via a PC.

DISPLAYS

Two large 4-digit LED displays for process value (red, and parameter value) and setpoint (green, and short texts) ensure easy reading.

In the Operating Level, the following displays can be called and changed, provided that this function has been enabled:

Internal setpoint, auto/manual mode, status of alarms 1 + 2, and the active program (1 to 4).

Similarly, the following displays are possible with an activated programmer:

Present setpoint, target setpoint of the active segment, remaining time of the active segment, remaining repeat cycles of the active program, auto/manual mode, status of alarms 1 + 2, and the active program (1 to 4).

In addition, indicator LEDs show the following operating conditions:

- Program running (RUN)
- Self-tuning function enabled (AT)
- Common event alarm (EVT)

Two further LEDs show the direction of setpoint change (increasing / hold / decreasing) or the output sense of the switching outputs.

Fault display

The following faults are signalled in the lower display:

- Device not configured
- Process value outside the measuring range
- Sensor fault

Information mode

The information mode can be called via the operating menu (input and module type, etc.).

MODULAR CONCEPT

Output 1 is always reserved as the controller output. Up to three additional modules can be inserted. Changing and retrofitting is possible on-site without recalibration. The modules are detected automatically, i.e. there is no need for recalibration.

Output 2

Relay, logic (SSR), mA, V or triac output is selectable, whereby the following functions are selectable:

- Second control output (cooling)
- Alarm 1 or 2 (direct/inverse)
- Alarm 1 and 2 (AND/OR-linked; direct/inverse)
- Program running (direct/inverse)
- Program control output

Output 3

Relay, logic (SSR), mA, V or triac output is selectable, whereby the following functions are selectable:

- Alarm 1 or 2 (direct/inverse)
- Alarm 1 and 2 (AND/OR-linked; direct/inverse)
- Analog output (process value or programmer setpoint)
- Program running (direct/inverse)
- Program control output

Option

Serial RS 485 interface (Modbus RTU) or external control input for programmer start/stop (potential-free contact).

UNIVERSAL INPUT

The input is configurable for all conventional signal and sensor types. With thermocouple or Pt 100 input, the resolution can be selected with or without decimals. Current and voltage inputs are scalable in the range -1999 ... 9999, with up to 3 decimals (999,9...9,999). The setpoint limits are adjustable within the measuring ranges. In case of a sensor fault, the control outputs are switched off (0% output).

Offset

For the purpose of measurement correction, a constant value can be added to the measurement signal.

CONTROLLER FUNCTIONS

Either PID, PD, PI or P behaviour is configurable.

Self-tuning function

The start-up tuning function (advance tuning) determines the best PID parameters by means of a 100% step change of the output, either at the push of a button (operating menu) or automatically at power-up.

The tuning attempt is started as soon as the control deviation exceeds 5% of the measuring range.

In addition, the fuzzy support can be activated, which drastically reduces overshoot with setpoint changes or load changes after the controller has been tuned.

Setpoint

Apart from the program setpoint, an internal setpoint can be adjusted from the front (adjustment can be disabled).

Manual operation

Switchover to manual operation is possible with the A/M key in the front panel. The front panel key can be disabled.

Control output limiting

The maximum output value for Output 1 is adjustable. During manual operation, the limit is not effective.

Operating sense

The operating sense for heating can be switched from 'inverse' to 'direct'. The operating sense for cooling is fixed to 'direct'.

Neutral zone (dead band)

With 3-point controllers and split-range operation, a neutral zone is adjustable in the range -20...+20%. Hereby, the two characteristics (heating / cooling) can overlap.

Overall dimensions (in mm)

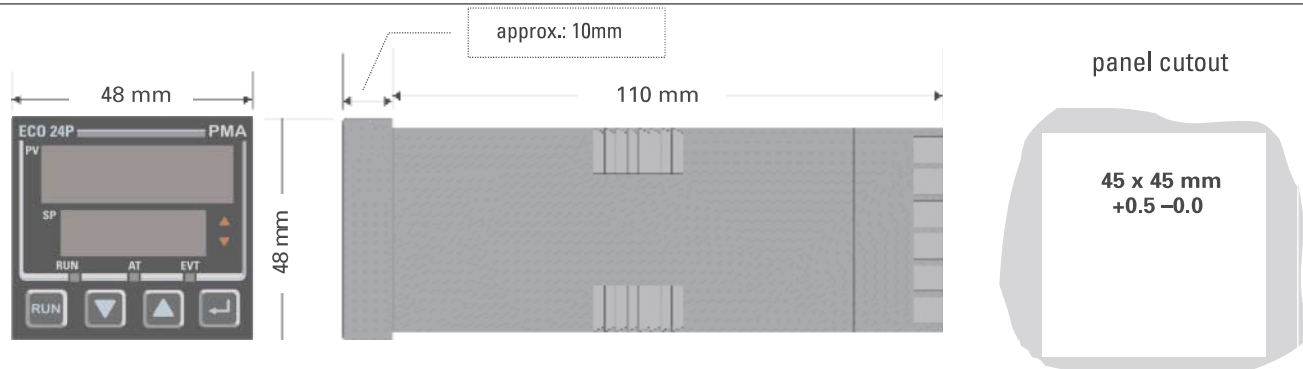

CONFIGURABLE ALARM OUTPUTS

Both alarm outputs work in the normally de-energized mode: Alarm relays or logic signals are energized in case of an alarm, and the corresponding red LED lights up.

The switching differential is separately adjustable. Alarm functions are configurable as absolute or relative measurement value alarms (min. or max.), bandwidth alarm (symmetrical to setpoint) or for control loop monitoring. The two alarm outputs can be AND or OR-linked, and be used as common alarms.

Furthermore, the alarm behaviour is configurable: Alarm suppression after power up and after a setpoint change. Normally energized or de-energized operating mode is also selectable.

Control loop alarm

Automatic detection if there is no response of the process value after a change in the output.

INTERFACE / DIGITAL INPUT (OPTION)

All parameters are accessible via the digital RS 485 interface with Modbus RTU protocol.

An external control contact can be used to start/stop the programmer.

GALVANIC ISOLATION

All outputs are galvanically isolated from each other, from the universal input, and from the power supply.

Important: An SSR output is not isolated from the universal input or from other SSR outputs!

TECHNICAL DATA

UNIVERSAL INPUT

Scanning cycle

250 ms

Measurement error

0,25% of measuring range \pm 1 digit (valid from 600 °C for Type B)

Digital input filter

0; 0,5...100 s, adjustable in steps of 0,5 s.

Connecting diagram

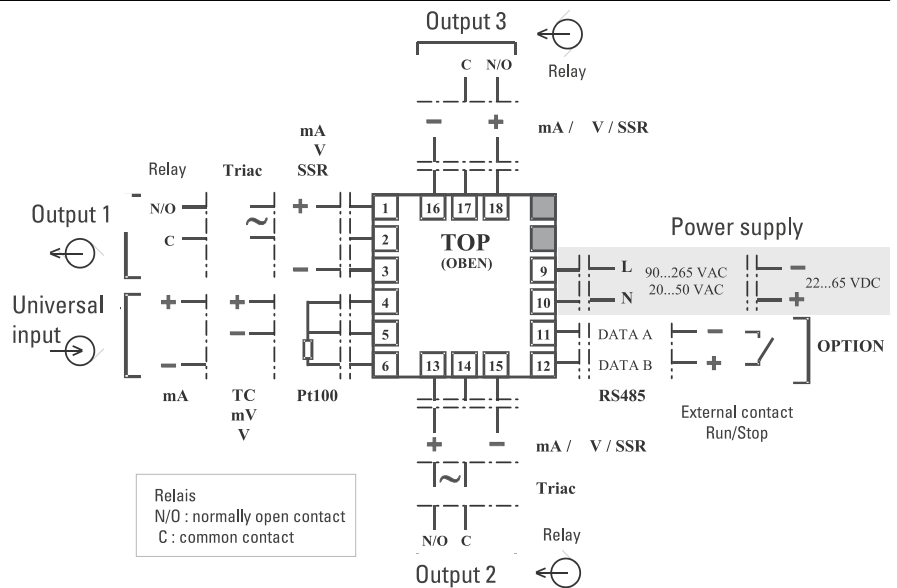

Thermocouples

Type		Measuring range	
Fe-CuNi	J	0...205,4 °C	32...401,7 °F
Fe-CuNi	J	0...450 °C	32...842 °F
Fe-CuNi	J	0...761 °C	32...1401 °F
Fe-CuNi	L	0...205,7 °C	32...402,2 °F
Fe-CuNi	L	0...450 °C	32...842 °F
Fe-CuNi	L	0...762 °C	32...1403 °F
NiCr-Ni	K	-200...760 °C	-328...1400 °F
NiCr-Ni	K	-200...1373 °C	-328...2503 °F
PtRh-Pt10%	S	0...1649 °C	32...3000 °F
PtRh-Pt13%	S	0...1650 °C	32...3002 °F
PtRh-Pt6%	B	100...1824 °C	212...3315 °F
Cu-CuNi	T	-200...262 °C	-328...503 °F
Cu-CuNi	T	0...260,6 °C	32...501 °F
Nicrosil-Nisil	N	0...1399 °C	32...2550 °F
W5Re-W26Re	C	0...2316 °C	32...4201 °F

Input resolution

Approx. 14 bits

Input resistance

10 V DC: 47 k Ω
20 mA DC: 4,7 Ω
Other ranges: >10 M Ω

MEASURING RANGES

Thermocouples

Characteristic

Temperature-linear

Sensor monitoring

Response time: 2 s

Controller outputs are switched off (output value 0%).

Cold-junction compensation

< \pm 0,7 °C at reference conditions.
< \pm 1 °C at operating conditions.

Temperature stability

< 0,01% / K change of ambient temperature

Source impedance effect

< 100 Ω : < 0,1% of measurement error (< 1000 Ω : < 0,5%)

Resistance thermometer

Sensor: Pt 100

Measuring ranges

0 ... 800 °C (32 ... 1472 °F)
0 ... 300 °C (32 ... 572 °F)
0 ... 100 °C (32 ... 212 °F)
-100...100 °C (-148...212 °F)
-100...537 °C (-148...999 °F)
-200...206 °C (-232...402 °F)

Characteristic: temperature-linear

Connecting principle: three-wire

Sensor current: approx. 150 µA

Sensor monitoring

Acts on sensor break and short circuit.

Response time: 2 s

Controller outputs are switched off (output value 0%).

Linearization error

< 0,2°C (typically 0,1 °C)
Without decimals: <±0,5 °C

Temperature stability

0,01% /K change of ambient temperature

Lead resistance effect:

< 0,5% of measurement error with 50 Ω/lead

Current and voltage

Measuring ranges:

0...20 mA, 4...20 mA,
0...50 mV, 10...50 mV,
0...5 V, 1...5V, 0...10V, 2...10V

Scaling

-1.999...9.999

Resolution

≥ 1 digit

Characteristic: linear

Break monitoring

Only with span start > 0!

Response time: 2 s

Controller outputs are switched off (output value 0%).

Temperature stability

< 0,01% / K change of ambient temperature

CONTROL INPUT (OPTION)

Connection of a potential-free contact or a TTL voltage level

Function

Programmer Start/Stop

Response delay: 0,25 s

TTL voltage level

= 0,8 V for Stop
≥ 2...24 V for Start

Contact

= 50 Ω for Stop
≥ 5 kΩ for Start

OUTPUTS 1, 2, AND 3

See text for a description of function.

Outputs 1 and 2

Relay, SSR driver, mA, V or triac

Output 3

Relay, SSR driver, mA or V

Relays

Contact type: potential-free, normally open

Contact rating:

Max. 2 A / 240 V AC, resistive load,
Min. 100 mA, 5 V AC/DC:

Electrical service life: 500.000 switching cycles at max. contact rating.

- If the relays operate external contactors, these must be fitted with RC snubber circuits to prevent excessive switch-off voltage peaks.

SSR driver

Power: >10 V at 20 mA load current

Triac

Operating principle: zero-crossing mode

Load voltage: 20...280 V_{rms}

Load frequency: 47...63 Hz

Load current: 0,01...1,0 A_{rms} (at 40 °C),
linear derating to 0,5 A_{rms} at 80 °C

Peak current: <25 A_{rms} (max. 1 full cycle)

Nominal forward voltage: < 1,5 V at full load

Critical voltage rise dv/dt: 500 V/ms

Peak reverse voltage: > 600 V_{rms}

Leakage current: <1 mA_{rms}

Input/output delay: 1 half cycle

Power factor: cos φ ≥ 0,5 (full load)

Standard signals

Error:

± 0,5 % for current output
± 0,25 for voltage output

Resolution: 10 bits

Scanning cycle: 250 ms

Standard current

Configurable 0...20 mA or 4...20 mA
Signal range: 3,68...20,32 mA (control output 4...20 mA)

Load: = 500 Ω

Load effect: = 0,1%/100 Ω

Standard voltage

Configurable 0...10 V / 0...5 V / 2...10 V
Signal range: 1,84...10,16 V (control output 2...10 V)

Load: ≥ 500 Ω

Load effect: = 0,25 % (2 kΩ);

= 0,25 % (500 Ω)

POWER SUPPLY

AC voltage

Voltage: 90...264 V AC

Frequency: 50/60 Hz

Power consumption: 7,5 VA

Universal supply

Voltage: 20...50 VAC, 50/60 Hz and 22...65 VDC

Power consumption: 7,5 VA or 4 W

CONTROL BEHAVIOUR

Proportional band: Pb = 0,5...999,9 % of measuring range; 0 = signaller function

Working point: 0...100 % (2-point and continuous controllers); -100...100 % (3-point and split-range controllers)

Integral action time T_n: 1 s...99 min 59 s...OFF

Derivative action time T_v: 0...99 min 59 s

Switching differential (Pb = 0):

0,1...10% of measuring range

Neutral zone (3-point and split-range controllers): -20...+20%, overlap of 'heating/cooling' possible

Switching duty cycle: 0,5; 1, 2, 4, up to 512 s

Operating sense: inverse ('heating') or direct ('cooling')

Output limiting: 0...100 % (only 2-point and continuous controllers)

Output response on sensor break or control loop error: controller outputs switched off.

Manual operation

Selectable via front panel key or control input.

Positioning range: (-100)...0...100 %

Setpoint functions

Program setpoint or internal setpoint, selectable

Self-tuning function

Method: configurable

Function: see text

Scanning cycle:

250 ms

PROGRAMMER

Number of programs

4, selectable from the front

Number of segments

16 per program

Segment types

Ramp / Hold / End

Segment duration

Max. 99 h, 59 min

Control output

Quantity: 1

Status: ON/OFF selectable per segment

Output: via Output 2 or 3

Start delay (timer)

Max. 99 h, 59 min

Start / Stop

Via front panel or control input

Program termination

Via front panel

Bandwidth monitoring

Effective during the Hold segment.

The program is stopped automatically, if the process value exceeds the defined bandwidth.

Setpoint at program start

Process value or internal setpoint

Behaviour at the end of a Hold segment

Continue program or wait for a start signal from the front panel.

Behaviour at program end

Stop or program repeat

Program cycles: 1...9999, or non-stop

Behaviour after mains failure

See text

ALARMS

See text for a description of the functions.

Quantity: 2 (min / max)

Hysteresis: 0...100 % of measuring range

COMMUNICATION

Configuration interface

Standard in every unit.

Serial interface (option)

RS 485, Modbus RTU

Controller addresses: 1...255 (Modbus)

Transmission speed: 1200...9.600 bits/s

Galvanic isolation: between inputs/outputs, and power supply

ENVIRONMENTAL CONDITIONS

Operating temperature: 0...55 °C

Relative humidity: 20...95 %, no condensation

Storage temperature: -20...+80 °C

Reference conditions

(for specified accuracy)

Ambient temperature: 20 °C ± 2 °C

Humidity: 60...70 % rH

Supply voltage: 100...240 VAC, 50 Hz ± 1%

Source impedance (TC): < 10 Ω

Lead resistance (Pt 100): < 0,1 Ω

TESTS

Electrical safety

According to DIN EN 61 010-1

Over-voltage category II

Contamination degree 2

Working voltage range 240 VAC

Electromagnetic compatibility

According to EN 61 326

GENERAL

Housing

Front dimensions: 48 x 48 mm

Mounting depth: 110 mm

Front panel cutout: 45 x 45 mm

Protection mode

Front: IP 66

Electrical connections

Screw terminals for max. 2,5 mm²

Weight: approx.

210 g

Options modules

Output modules can be retrofitted without recalibration. Module function is determined by jumpers. Ordering data for the Options modules is given under 'Accessories'.

ECO24P

Ordering code

ECO-24P - - - **00**

Input signal type		
Universal input configured for:	Pt100 or mV	1
	Thermocouple	2
	DC mA	3
	DC Volt	4
Output 1		
Relay module		1
SSR / Logic module		2
Continuous module configured for:	0 - 10 V	3
	0 - 20 mA	4
	0 - 5 V	5
	4 - 20 mA	7
Triac		8
Option Output 2		
Not used		0
Relay module		1
SSR / Logic module		2
Continuous module configured for:	0 - 10 V	3
	0 - 20 mA	4
	0 - 5 V	5
	4 - 20 mA	7
Triac		8
Option Output 3		
Not used		0
Relay module		1
SSR / Logic module		2
Continuous module configured for:	0 - 10 V	3
	0 - 20 mA	4
	0 - 5 V	5
	4 - 20 mA	7
Option control input / RS 485		
Not used		0
RS485		1
Digital input (programmer Start/Stop)		3
Supply voltage		
100 - 240 V AC		0
24 - 48 V UC		2

Accessories ECO24P

Ordering code

Options module	
Relay module	ECO24P - C10
SSR / Logic module	ECO24P - C50
Continuous module mA/V/DC	ECO24P - C21
Triac	ECO24P - C80
Digital input	ECO24P - W03
RS485 interface	ECO24P - W06



PMA

Prozess- und Maschinen- Automation GmbH
 P.O. Box 31 02 29
 D-34058 Kassel
 Tel.: +49 - 561- 505 1307
 Fax: +49 - 561- 505 1710
 E-mail: mailbox@pma-online.de
 Internet: http://www.pma-online.de

Your local representative: