

Transmitter L5

With ceramic cell for level measurement

Self monitoring measuring cell

Local display and adjustment

Usable turn down of 20 : 1

Output signal selectable for level or differential pressure

Explosion protection type EEx ia IIC

Smart with HART

GENERAL

Transmitter L5 is suitable for hydrostatic level measurement as well as for gauge, vacuum or differential pressure measurements with liquids, vapours and gases. Spans between 5 and 3000 mbar are available with three measuring cells. The output is a standard 4...20 mA signal proportional to the applied level (e.g. in a horizontal cylindrical container) respectively to the differential pressure. The microprocessor-controlled electronics work on the two-wire principle. Transmitter energization is by means of a DC voltage.

DESCRIPTION

Transmitter L5 comprises the measuring cell, a mounting respectively pipe flange and a process flange with seals and the electronic housing.

The measuring cell is designed as a single-compartment device. Its body and both diaphragms are made of sintered aluminium oxide ceramic.

Superior features are offered by the corrosion resistant ceramic cell.

- With sticking media easy cleaning of the smooth ceramic diaphragm.
- The thickness of the ceramic diaphragm and its superior resistance against mechanical shocks exclude damage under normal operating conditions.

The level / pressure signal is detected as capacitance via the position of the diaphragms.

The measuring cell is built-in in such way, that the diaphragm surface more or less is even with the seat of the gasket.

The lower respectively the reference pressure is fed to the process flange via the 1/4-18 NPT thread.

Process flanges wetted by the process media, can be of:

- Stainless steel
- Stainless steel coated with ECTFE
- Hastelloy C

Process seals are available in FKM (e.g. Viton®), EPDM (NBR) or PTFE on Hastelloy C.

Microprocessor-controlled electronics provide high-precision signal processing and monitoring, from the sensor to the signal output.

Measuring cell monitoring, which only is possible with ceramic sensor technology, offers outstanding safety for industrial processes.

Electronics and terminal compartment are hermetically separated, i.e. with the terminal compartment open, the electronics remain protected from environmental contamination.

Parameter are adjustable by means of 4 push buttons or with an external hand-held control unit.

Transmitter L5 can be supplied with a digital indicator. Retrofitting is possible.

Depending on the measuring cell span, a turn-down of 20 : 1 is possible. This means for example, that the 100 mbar cell is adjustable downwards to a span of 5 mbar¹⁾.

Intrinsic safe (EEx) versions are available.

¹⁾ increased conformity error

OPERATING PRINCIPLE

Measuring cell

The measuring cell consists of the ceramic body and the two ceramic pressure diaphragms. The compartment between the two diaphragms is filled with Silicone- or inert oil. Any change in the differential pressure causes a displacement of both diaphragms, which is measured directly as a capacitance. The difference between capacitance C1 and C2 corresponds to the applied pressure.

Self monitoring

Because of temperature proportional expansion of the oil volume, the sum of capacitances C1 and C2 also corresponds to the process temperature. An integrated temperature measurement in the cell provides the actual process temperature value. The microprocessor monitors continuously and provides an alarm signal in case of discrepancy. The alarm acts on the analogue output signal and can be set for upscale, downscale or off (keeping the process value).

TECHNICAL DATA

INPUT

Dimensions: mbar

Cell	2D	3F	3H
Nominal range	0...100	0...500	0...3,000
Span	5...100	25...500	150...3,000
Span start	-100...95	-500...485	-3,000...2,850
Nominal pressure	PN 16	PN 100	
Filling media	Silicone-oil	Mineral oil	

Static pressure

up to max. PN of corresponding measuring cell

Minimum pressure

100 mbar abs.

Static pressure effect

With symmetrical load: 0.2 % at PN for span start and span.

Overload limit: PN

Process media

Liquids, vapours and gases (aggressive and corrosive media with suitable material selection).

Fig. 1 Dimensions

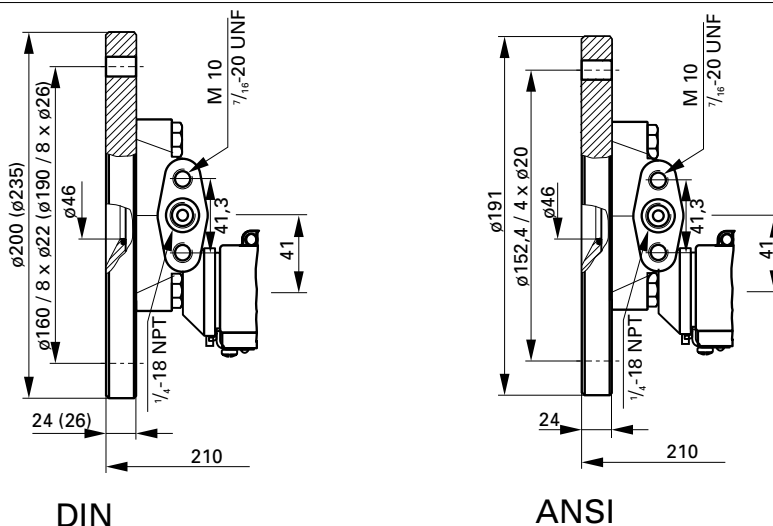

Materials

Diaphragm

- Ceramics

Gasket

- FKM (e.g. Viton®)
- NBR (EPDM)
- PTFE on Hastelloy C

Pipe flange

- Stainless steel SS 316 L (1.4435)
- Stainless steel coated with ECTFE
- Hastelloy C-276 (#2.4819)

Process flange

- Stainless steel SS 316 L (1.4435)

Bolts and nuts for process flange

- Stainless steel SS 316 Ti (1.4571)

Blind stopper/Venting valve

- SS 316 (order separately)

OUTPUT

Output signal 4...20 mA

Output current limiting: 20.5 mA

Lowest value: 3.8 mA (4 mA selectable)
For alarm: selectable 3.6 mA; 21.5 mA;
"hold value"

Ripple: ±0.25 % fsd

HART protocol: $U_{pp} < 200 \text{ mV}$ (47 Hz ...125 kHz)
and $U_{rms} = 2.2 \text{ mV}$ (500 Hz up to 10 kHz)

CHARACTERISTIC

- proportional to the level
- proportional to the applied differential pressure
- free programmable

Conformity error: <0.1 %

Terminal based for nominal span of cell

For TD 100:1 Conformity error

$$0,1\% \frac{0,1 \text{ nominal value}}{\text{set span}}$$

(Hysteresis and reproducibility included)

Long term drift: 0.1 % / a

MAXIMUM LOAD

$$R_{Load} \frac{U_{Supply} - U_{Min} - V}{0,023 \text{ A}} R_{Load}$$

Load effect: < 0.01% per 100

DYNAMIC RESPONSE

Rise time: depending from cell and span
0.4 up to 1.6 s

Average delay: depending from cell, 0.5 up to 2 s

Damping

0 to 16 s adjustable by switch,
per SW up to 40 s adjustable

Fig. 2 Electrical connection

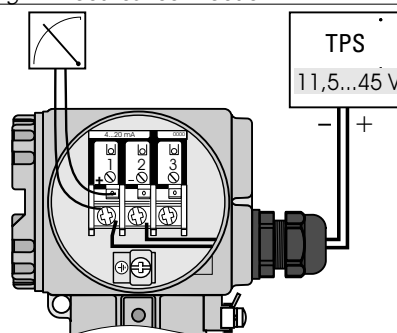

POWER SUPPLY

SUPPLY VOLTAGE

11.5...45 VDC
11.5...30 VDC for EEx

Supply voltage effect

0.1 % between 11.5...45 VDC

Ripple

No effect for $U_{pp} \leq \pm 5\%$ within the nominal supply range.

EXPLOSION PROTECTION

Protection type: ATEX  G 1 / 2
EEx ia IIC T4/T6

Certificate of conformity

KEMA 03ATEX1542

Installation

Transmitter in zone G1 /2 hazarded area,

ENVIRONMENTAL CONDITIONS

TEMPERATURE LIMITS

Nominal temperature: -38 °C...+85 °C

For storage: -40 °C...+100 °C

Temperature effects

on span start and span
(incl. media temperature)
 $\pm 0.02\%$ / 10 K within -10 °C...+60 °C
and
 $\pm 0.1\%$ / 10 K within -40 to -10 °C and
within +60 to 85 °C

Max. process temperature at the measuring cell

-40°C...+85°C , for short periods 120°C,
depending on process seal
(+70 °C with EEx ia IIC T4)

Process seal	Lower temperature limit
FKM (e.g.Viton®)	-20 °C
EPDM (NBR)	-40 °C
PTFE	-40 °C

Relative humidity

100 % r.H. no condensation

Climatic category

class GPC to DIN 40040

Vibration effect

< 0.1 % (tested to DIN IEC 68, part 2-6,
referred to nominal span of cell).

**ELECTROMAGNETIC
COMPATIBILITY**

Complies with EN 50082-2 and NAMUR
with 30 V/m
Tests to IEC 801-1 up to 801-6
Electromagnetic radiation to EN 50081-1
CE-labelled

GENERAL

HOUSING FOR ELECTRONICS

Di-cast aluminium AlSi 12 free of copper,
with fully chromated surface, epoxy
polyester coated, seals made of NBR.

HOUSING PROTECTION TYPE

IP 65 to DIN 40050

PROCESS COUPLING

Pipe flange: DN 80 PN40
ANSI 3 inch 150 lbs
Process flange: femal ¼-18NPT

ELECTRICAL CONNECTION

Screw terminals for 2,5 mm² via cable
gland

WEIGHT

appr. 10 kg

ACCESSORIES

Instructions for L5

Further documentation

Instructions for PD5/6 with HART

Atex-Safety instructions 9499-047-11101

FITTINGS

Blind stopper

Set of 2
Material: stainless steel 1.4401(SS 316)
9407-290-00011

Venting valve

Set of 2 units
Material: stainless steel 1.4401(SS316)
9407-290 00021



Version with HART protocol

No display, non EEx	5
EEx ia IIC T4/T6	6
With LCD display, non EEx	7
With LCD display, EEx ia IIC T4/T6	8

Mounting flange: material / seal

Stainl.steel 1.4435 / FKM (e.g. Viton®)	0
Stainl.steel 1.4435 / NBR (EPDM)	1
ECTFE coated / FKM (e.g. Viton®)	2
ECTFE coated / NBR (EPDM)	3
ECTFE coated / PTFE on Hastelloy	4
Hastelloy C / FKM (e.g. Viton®)	5
Hastelloy C / NBR (EPDM)	6
Hastelloy C / PTFE on Hastelloy	7

Calibration / unit

Calibrated from 0...nominal value of cell in mbar/bar, linear	0
Calibrated from 0...nominal value of cell in kPa/Mpa, linear	1
Calibrated from 0...nominal value of cell in mm H2O, linear	2
Calibrated from 0...nominal value of cell in inch H2O, linear	3
Calibrated from 0...nominal value of cell in kgf/cm2, linear	4
Calibrated from 0...nominal value of cell in psi, linear	5
Start, span in clear text, e.g.. %, linear/ square root/cylindric	9

Cell, nominal value / flange DN 80

Nominal pressure 16 bar		
	100 mbar	1
Nominal pressure 100 bar		
	500 mbar	2
	3000 mbar	3

Cell, nominal value / flange ANSI 3in, 150 lbs

Nominal pressure 16 bar		
	100 mbar	4
Nominal pressure 100 bar		
	500 mbar	5
	3000 mbar	6



Deutschland

PMA Prozeß- und Maschinen- Automation GmbH
Miramstrasse 87, D-34123 Kassel

Tel./Fax: (0561) 505 - 1307/-1710
E-mail: mailbox@pma-online.de
Internet: http://www.pma-online.de

Your local distributor: