



## *rail line* System components

Fieldbus coupler for UNIFLEX CI 45,  
KS 45, and TB 45

Port for PROFIBUS-DP  
Ethernet MODBUS/TCP  
Compact design  
Centralized energization  
Power supply modules

*rail line*

### FEATURES

- Fieldbus port for rail line function modules
  - Transmitter UNIFLEX CI 45
  - Universal controller KS 45
  - Temperature limiter TB 45
- Supported fieldbuses:
  - PROFIBUS DP with DPV1 protocol
- Ethernet TCP/IP with MODBUS/TCP protocol
- Compact design, only 22,5 mm wide
- Clips onto top-hat DIN rail
- Plug-in screw terminals or spring-clamp connectors
- Direct communication between rail-mounted transmitters
- Centralized 24 VDC supply
- Function modules replaceable during operation (hot swap)
- Central configuration support via BlueControl®
- 2 data formats (integer & float)

### APPLICATIONS

- ⊕ Decentralized acquisition of process signals and control of processes
- ⊕ Remote I/O system
- ⊕ Linking into fieldbus systems

- ⊕ Component-oriented system structure with distributed intelligence

### DESCRIPTION

#### Construction

A *rail line* system consists of a fieldbus coupler, and various rail-mounted function modules, for example:

- UNIFLEX CI 45 transmitters for precise and cost-effective signal detection and processing tasks.
- Universal controller KS 45 for a wide range of control tasks
- Temperature limiter TB 45 for reliable monitoring/limiting tasks

Connections between the modules are made by means of a bus connector clipped to the top-hat rail.

#### Power supply

System energization (24 VDC) is provided via the fieldbus coupler from a central power supply. The function modules are supplied internally.

#### Mounting

The bus connectors are clipped to one end of the top-hat rail. The *rail line* modules are also clipped to the rail, and pushed up close to each other, thus providing a connection to the bus. Unmounting the modules is just as simple.

All connections are of the plug-in type, so that a module can be replaced very quickly without disturbing the wiring.

#### Interfaces and Engineering Tools

The fieldbus coupler as well as the connected function modules, can be configured with the BlueControl® software via the BluePort® interface. System data can be stored in a project file.

#### Data exchange

The process data that is to be transmitted can be defined in the Engineering for every function module. Up to 15 values can be read or written. The data are always available in the bus coupler, thus ensuring fast responses to requests.

Similarly, the fieldbus interface can be used to transfer the complete Engineering.

#### Construction

Up to 16 function modules can be connected to each fieldbus coupler. If additional power supply modules are fitted, up to 62 function modules can be addressed by a single fieldbus coupler.

## TECHNICAL DATA

### SYSTEM STRUCTURE

A basic system consists of a fieldbus coupler and several stack-mounted function modules.

Available modules	<b>UNIFLEX CI 45, KS 45, TB 45</b> (versions with system interface)
Number of modules per bus coupler:	16 *
Connection:	direct, via system bus in the top-hat rail
expandable:	to 62 **
Distribution in levels:	max. 4
Max. stacked length: Distance between levels:	10 m max. 3 m

\* preliminary (depends on power requirements)

\*\* via power supply modules (max. 16 units per power supply module, see above)

### FIELDBUS COUPLER

#### PROFIBUS-DP

PROFIBUS-DP slave interface to IEC 61158 Reading & writing of process data, parameters, and configuration data for DPV0.

A-cyclical DPV1 services for Master Classes 1 and 2

Connection via PROFIBUS Sub-D connector

Fig.: 3 : Buscoupler PROFIBUS DP



Physical connection:	RS 485
Transmission speed:	9,6...1200 kBit/s self-adapting
Address range:	1...99 via rotary switch
Number of units per bus segment:	32

Fig.: 1: Dimensions RL DP

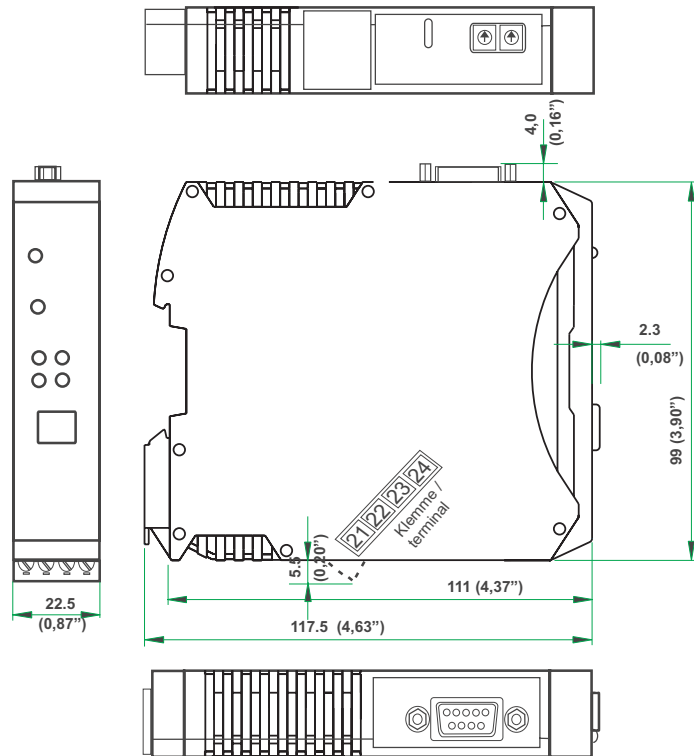

Fig.: 4: Connection buscoupler

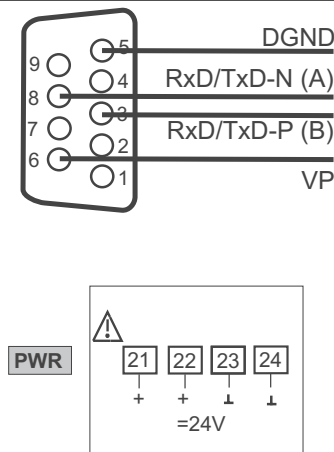
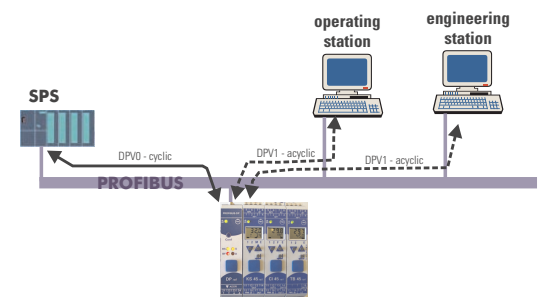

Fig.: 2: communicative possibilities



#### Cable lengths

Bit rate	max. length per segment
9,6 ... 93,75 kbits/s	1200 m
187,5 kbits/s	1000 m
500 kbits/s	400 m
1,5 Mbits/s	200 m
3 ... 12 Mbits/s	100 m

#### Terminating resistor

external, fitted in connector

#### Cable

to IEC 61158, Type A.

#### Protocol

- PROFIBUS DPV1

#### GSD file

on PMA homepage

#### DPV1 functions

The extended PROFIBUS functions for DPV1 can be used for the standardized, non-cyclical transmission of parameters, etc. RLDP supports the following non-cyclical DPV1 services:

- a connection to the DP Class 1 Master (e.g. PLC): Read, Write, Alarm, Alarm\_Ack.
- two connections to the DP Class 2 Master (e.g. operating/engineering stations): Initiate, Abort, Read, Write

Upload/download of an Engineering via the PROFIBUS between BlueControl® and RLDP is possible via the DPV1 services (for PROFIBUS links supplied by Hilscher, e.g. CIF50-PB, CIF60-PB).

## DISPLAY AND OPERATION

Indicator LEDs

OK / Err. (3-colour):	<b>device status</b>
BS (yellow):	<b>fieldbus status</b>
BF (red):	<b>faulty parameter or configuration telegram</b>
S (yellow):	<b>system bus status</b>
D (yellow):	<b>diagnosis</b>

### Address selector

2 rotary coding switches 0...99

## ETHERNET MODBUS/TCP

Ethernet interface with TCP/IP protocol

Reading & writing of process data, parameters, and configuration data via application protocol MODBUS/TCP. Connection via RJ45-connector

Fig. 5 Bus coupler Ethernet



### Network connection

Ethernet RJ45 femal connector  
10/100BaseT to IEEE802.3

Fig. 6: Connections RL ETH

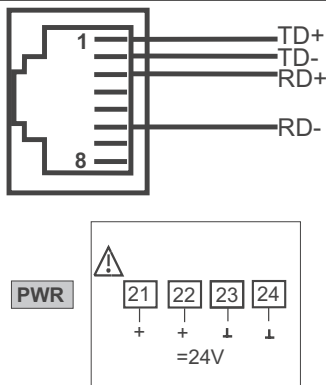

### Transmission speed

10 / 100 MBit/s

Fig. 7: Dimensions RL ETH

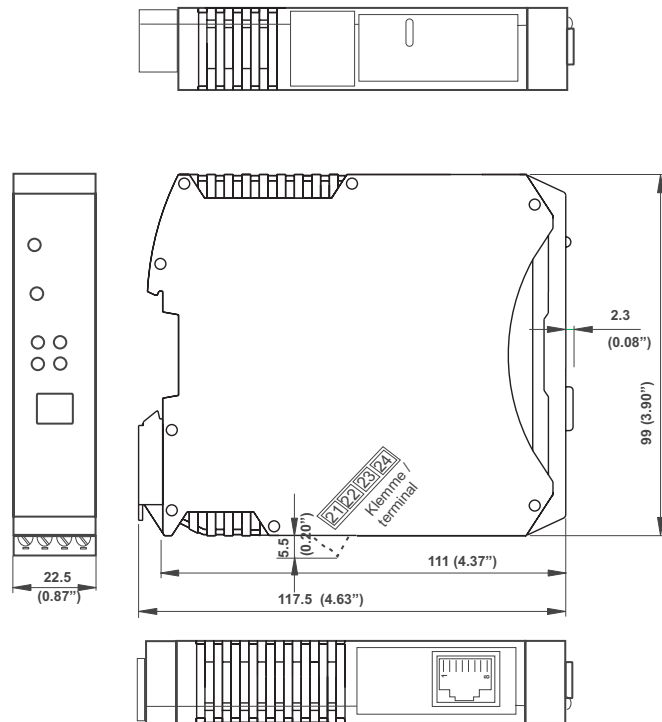

### Cable

Copper conductors, twisted pair, 4 wires  
Type Cat5

### Permissible cable lengths

Ethernet segment length: 100 m (with Cat5 cables)

### Protocol

TCP/IP protocol  
MODBUS/TCP - Server via port 502  
Connectable to 4 Clients at the same time  
max. 16 connections

## DISPLAY AND OPERATION

Indicator LEDs

ok/err. (3-colour):	<b>device status</b>
BS (yellow):	<b>fieldbus status</b>
S (yellow):	<b>system bus status</b>
RX (yellow):	<b>Ethernet data receiving</b>
TX (yellow):	<b>Ethernet data transmission</b>

### Address selection

by means of Engineering Tool BlueControl® or BOOTP protocol

## GENERAL TECHNICAL DATA

### POWER SUPPLY

#### 24 VDC supply

Voltage:	19,2...30 VDC
Power consumption of bus coupler:	max. 4 W
Power for module energization:	max. 5 A

Supply only with safe low voltages (SELV)  
Protected against reversed polarity and overvoltage

#### Behaviour with power failure

System configuration: Permanent storage in EEPROM

## BLUEPORT® FRONT INTERFACE

Connection to the module front via a PC adapter (see 'Accessories').

The BlueControl® software enables

- the fieldbus coupler and
- the connected modules

to be configured, parameters set, and operated.

## SYSTEM INTERFACE

Internal bus for connecting modules via the system interface.

Connection via bus connector fitted in the top-hat rail.

Busterminator for the systembus with use of power supply modules	100 Ω, to be mounted external
--	-------------------------------

## ENVIRONMENTAL CONDITIONS

### Protection class

Module front: IP 20  
Housing: IP 20  
Terminals: IP 20

### Permissible temperatures

Operation: -10...55 °C  
Storage: -25...60 °C  
Transport: -25...85 °C

### Humidity

KUF to DIN 40 040  
75% yearly average, no condensation

### Shock and vibration

Vibration test Fc (DIN EN 60068-2-6)  
Loading: 5 g  
Duration: 2 h in every axis

### Shock test Ea (DIN EN 60068-2-27)

Shock: 25 g  
Duration: 11 ms

### Electromagnetic compatibility

Complies with EN 61 326-1 for continuous, unattended operation.

### Emissions:

- within the limits for Class A devices.

### Immunity:

complies with the test requirements for devices used in industrial areas.

## GALVANIC ISOLATION

Supply voltage, fieldbus, and logic circuits are isolated from each other.  
Insulation voltage: 500 VDC

## GENERAL

### Housing front

Material: Polyamide PA 6.6  
Flammability class: V0 (UL 94)

### Connecting terminals

Material: Polyamide PA  
Flammability class: V0 (UL 94) for screw terminals V0 (UL 94) for bus connectors

### System bus connectors

Insertions under load: max. 5

### Electrical safety

Complies with EN 61 010-1:Over-voltage category II  
Contamination degree 2  
Protection class II

### Electrical connections

Plug-in connector strips with choice of terminal type:

- Screw terminals or spring-clamp terminals, both for lead cross-sections from 0,2 to 2,5 mm<sup>2</sup>.

### Mounting

Clip-on rail mounting (35 mm top-hat rail to EN 50 022).  
Locked by means of metal catch in housing base.  
Stacked mounting possible.  
Mounting position: vertical

### Weight:

0,16 kg

### Standard accessories

- Operating instructions
- Bus connector for fitting into top-hat rail
- Connection for power supply: screw terminal connector

### CERTIFICATIONS

- CE (standard)
- UL / cUL

## ACCESSORIES

### POWER SUPPLY MODULE

#### Applications

- Supplementary supply of additional modules
- Distribution in different installation levels
- Provision of separated potential levels

#### \* Note:

- No stacked mounting with other system modules permitted (fieldbus coupler, other supply modules)
- Bus connection has to be realized locally by means of plugs for bus connection (see accessories 4, 5)
- Line termination for system bus recommended ( 100Ω)

Available modules: UNIFLEX CI 45, KS 45, TB 45 (versions with system interface)

Number of modules  
16 \*

per supply module:

Connection: direct, via system bus in the top-hat rail

Performance data: see fieldbus coupler

## BLUECONTROL® (ENGINEERING TOOL)

PC software package for system configuration, parameter setting, and operating (commissioning) the fieldbus coupler.

Central Engineering Tool for configuring, parameter setting, and operating the connected function modules.

Fig.: 8: System assistant

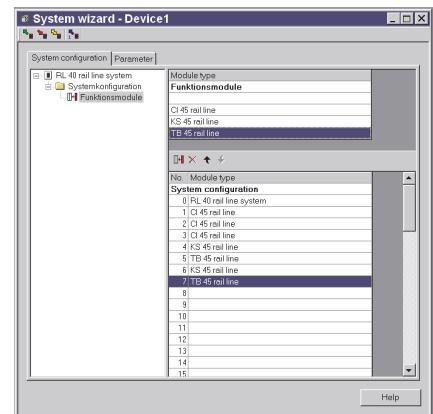

**Software requirements:**  
Windows 95/98/NT/2000/XP

**Hardware requirements:**  
A special PC adapter (see 'Additional Accessories') is required for connecting to the device.  
Updates and demo software from:  
[www.pma-online.de](http://www.pma-online.de)

## ORDERING INFORMATION SYSTEMCOMPONENTS

### System components

Fieldbus coupler PROFIBUS DP	<b>RL40-112-00000-000</b>
Fieldbus coupler PROFIBUS DP, UL / cUL certified	<b>RL40-112-00000-U00</b>
Fieldbus coupler Ethernet MODBUS/TCP	<b>RL40-114-00000-000</b>
Fieldbus coupler Ethernet MODBUS/TCP, UL / cUL certified	<b>RL40-114-00000-U00</b>
Power supply module	<b>RL40-119-00000-000</b>
Power supply module UL / cUL certified	<b>RL40-119-00000-U00</b>

<b>Operation note function modules:</b>	<b>with system interface</b>
Transmitter UNIFLEX CI 45	CI45-1xY-2xxxx-xxx ↳ Y = 3,5
Universal controller KS 45	KS45-1xY-2xxxx-xxx ↳ Y = 1,3,5
Temperature limiter TB 45	TB45-1xY-2xxxx-xxx ↳ Y = 1,3

➤ Please also order the associated documentation:

### DOCUMENTATION

Description	Order-No.
Operating instructions rail line System PROFIBUS (D)	9499-040-77118
Operating instructions rail line System PROFIBUS (E)	9499-040-77111

### ACCESSORIES

Description		Order-No.
① connector-set screw terminal	4 pcs.	9407-998-07101
② connector-set spring-clamp terminal	4 pcs.	9407-998-07111
③ Top-hat rail bus-connector	1 pcs.	9407-998-07121
④ Plug for bus connection, inverted, connections at left, horizontal cable entry	1 pcs.	9407-998-07131
⑤ Plug for bus connection, connections at right, vertical cable entry	1 pcs.	9407-998-07141

### ADDITIONAL ACCESSORIES

Description	Order-No.
PC adapter for the BluePort® front interface	9407-998-00001
USB serial adaptor (USB to RS 232)	9407-998-00081
Converter RS 232 to RS 422/485	galv. isolated ADAM-4520-D
BlueControl® Mini	<a href="http://www.pma-online.de">www.pma-online.de</a>
BlueControl® with Basic license rail line	9407-999-12001
BlueControl® with Expert license rail line	9407-999-12011



**Germany**

PMA  
Prozeß- und Maschinen-Automation GmbH  
Miramstraße 87, D-34123 Kassel  
Tel.: +49 561 505 - 1307  
Fax: +49 561 505 - 1661  
E-mail: [export@pma-online.de](mailto:export@pma-online.de)  
Internet: <http://www.pma-online.de>

**Your local distributor**